

THIS DRAWING IS UNPUBLISHED. RELEASED FOR PUBLICATION 20
 © COPYRIGHT 20 BY TYCO ELECTRONICS CORPORATION. ALL RIGHTS RESERVED.

LOC	DIST	REVISIONS			
P	LTR	DESCRIPTION	DATE	DWN	APVD
FT	0	C3	REVISED PER ECO-10-009379	05MAY2010	HMR CR

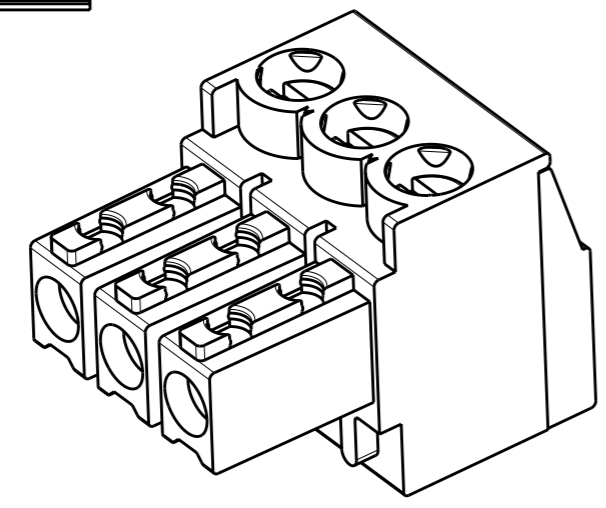
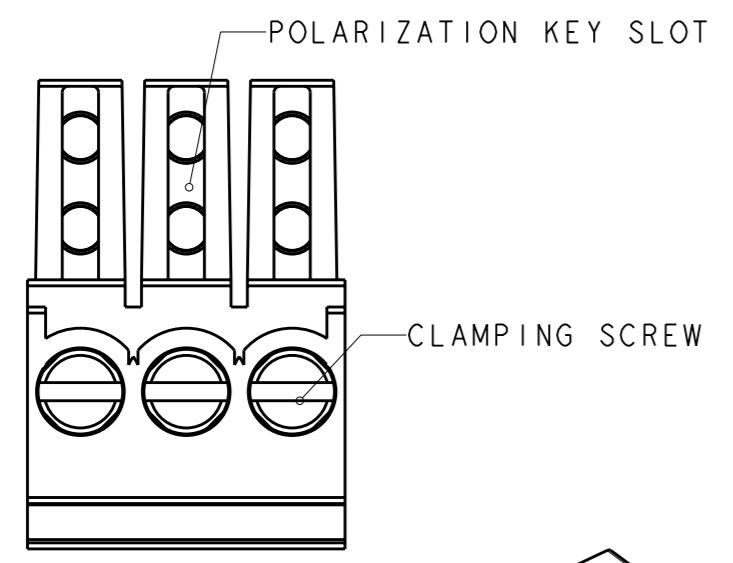
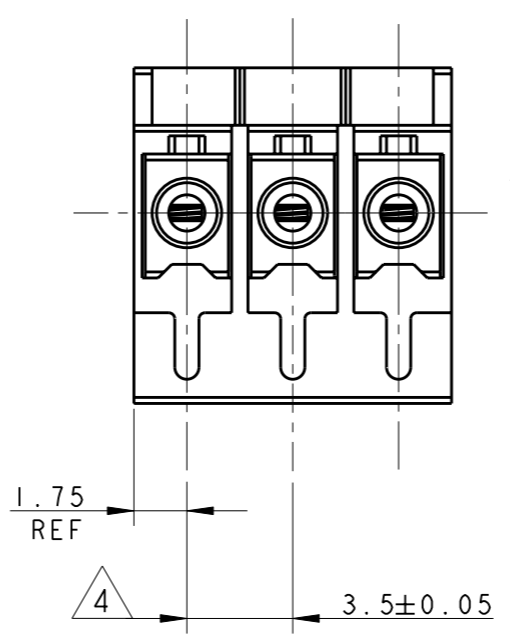
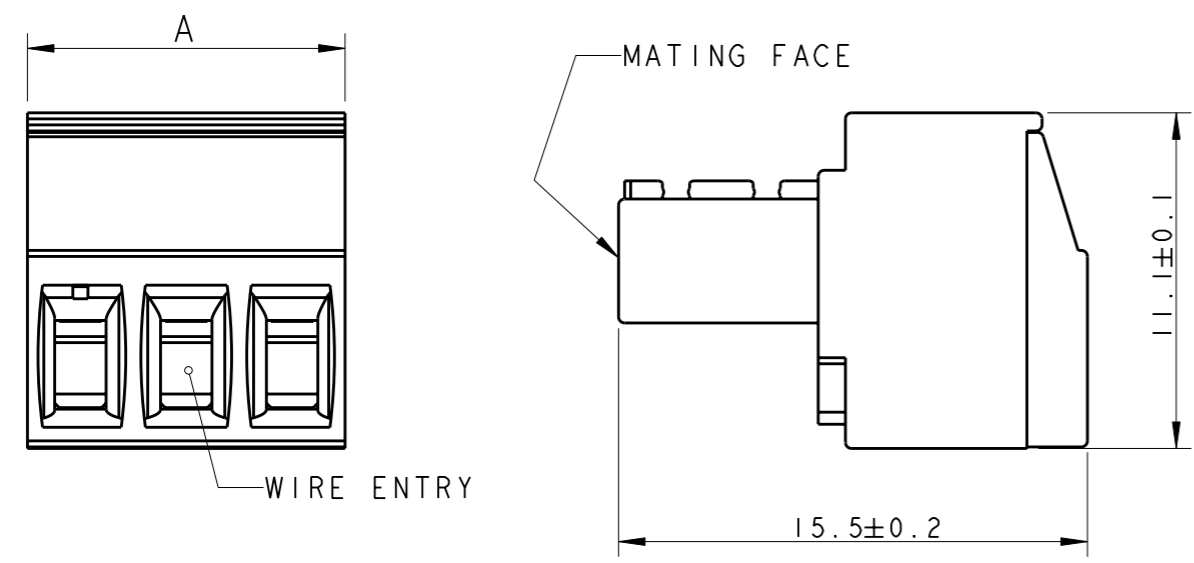

P/N 284506-3 AS SHOWN

- 1 MATERIALS AND FINISH
 HOUSING : PA 6.6, UL 94-V0, COLOR GREEN
 CLAMP : BRASS, NICKEL PLATED.
 TERMINAL : BRASS, PLATING: SEE TABLE.
 CONTACT SPRING : PHOSPHOR BRONZE, TIN PLATED
 CLAMPING SCREW : M2, BRASS, NICKEL PLATED
- 2 END-TO-END STACKABLE WITHOUT LOSS OF CENTERLINE SPACING
- 3 WIRE SIZE RANGE: 14-30 AWG.
- 4 NOT CUMULATIVE TOLERANCE
- 5 PRELIMINARY - NOT FOR PRODUCTION.
- 6 WITH SPECIAL CODING LOCATED IN POSITIONS 1 AND 3. MATES WITH 3-284512-8.
- 7 WITH SPECIAL CODING LOCATED IN POSITION 2. MATES WITH 3-284512-9.

TERMINAL PLATING	A	NO OF POSN	PART NUMBER
TIN	10.5	3	3-284506-0
TIN	10.5	3	2-284506-9
0.8 MICRON GOLD	10.5	3	2-284506-8
GOLD FLASH	24.5	7	2-284506-7
0.2 MICRON GOLD	42.0	12	2-284506-6
TIN	87.5	25	2-284506-5
TIN	84.0	24	2-284506-4
TIN	80.5	23	2-284506-3
TIN	77.0	22	2-284506-2
TIN	73.5	21	2-284506-1
TIN	70.0	20	2-284506-0
TIN	66.5	19	1-284506-9
TIN	63.0	18	1-284506-8
TIN	59.5	17	1-284506-7
TIN	56.0	16	1-284506-6
TIN	52.5	15	1-284506-5
TIN	49.0	14	1-284506-4
TIN	45.5	13	1-284506-3
TIN	42.0	12	1-284506-2
TIN	38.5	11	1-284506-1
TIN	35.0	10	1-284506-0
TIN	31.5	9	284506-9
TIN	28.0	8	284506-8
TIN	24.5	7	284506-7
TIN	21.0	6	284506-6
TIN	17.5	5	284506-5
TIN	14.0	4	284506-4
TIN	10.5	3	284506-3
TIN	7.0	2	284506-2

<small>THIS DRAWING IS A CONTROLLED DOCUMENT FOR TYCO ELECTRONICS CORPORATION IT IS SUBJECT TO CHANGE AND THE CONTROLLING ENGINEERING ORGANIZATION SHOULD BE CONTACTED FOR THE LATEST REVISION.</small>		DWN 05FEB2002 E. ZANOLINI CHK 05FEB2002 E. ZANOLINI APVD 05FEB2002 D. BIEVENOUR		Tyco Electronics Harrisburg, PA 17105-3608	
DIMENSIONS: mm		TOLERANCES UNLESS OTHERWISE SPECIFIED: 0 PLC ±.3 1 PLC ±.3 2 PLC ±.25 3 PLC ±. 4 PLC ±. ANGLES ±2		NAME TERMINAL BLOCK PLUG STACKING 3.5mm PITCH	
		PRODUCT SPEC 108-20166		SIZE CAGE CODE DRAWING NO RESTRICTED TO A3 00779 C-284506	
MATERIAL 		FINISH 		APPLICATION SPEC 114-20079	
CUSTOMER DRAWING				WEIGHT - SCALE 4:1 SHEET 1 OF 1 REV C3	